



HEAT PUMP

Operation & Installation Manual

Preface



- This manual includes all the necessary information regarding the installation and maintenance of this product. Please take the time to read it through before operating.
- When installing the hot water cylinder, please follow the Instructions as documented in this manual.
- Once the installation is complete, check that all connections are secure before the power is turned On.
- The installer is to explain to the end user how to operate and maintain the unit in accordance to this instruction manual.
- It is important that the installation and operational instructions laid out in this manual are strictly adhered to.
- A maintenance programme must be carried out as recommended in this manual.
- Fail to comply with these recommendations will invalidate the warranty.
- This manual could be subject to change without prior notice, if it is felt that product improvements are to be carried out.
- If the supply cord is damaged, it must be replaced by the manufacturer, its service agent or similarly qualified personnel in order to avoid a hazard.
- This appliance is not intended for use by persons (including children) with reduced physical, sensory or mental capabilities, or lack of experience and knowledge, unless they have been given supervision or instruction concerning use of the appliance by a person responsible for their safety.
- Children should be supervised to ensure that they do not play with the appliance.



Content

1. Safety Precautions	1
2. Specifications	3
2.1) appearance	3
2.2) characteristic	3
2.3) principle	4
2.4) dimensions	5
2.5) performance parameter	6
3. Function presentation	7
4. Installation	8
4.1) pipeline connection sketch	8
4.2) transportation	9
4.3) installation space	10
4.4) cable connection	12
4.5) trial running	12
4.6) seismic restraints	12
5. Usage	13
5.1) function of wire controller	13
5.2) usage of wire controller	15
6. Maintenance and repair	24
6.1) maintenance	24
6.2) trouble shooting guide	25
6.3) major service	26
6.4) water supplies, water chemistry and water quality	27
6.5) product warranty	28
7. Appendix	30
7.1)caution	30
7.2)the method of grounding	31
7.3)use of the P&T valve	31
7.4)drain out the water in the storage tank	32
7.5)use of the overheating protector	32

1. Safety Precautions



To prevent personal injury and avoid causing damage to the unit, please take the time to read the information documented in this manual.

Icon	Meaning
 WARNING	A wrong operation may lead to serious injury or death.
 ATTENTION	A wrong operation may lead to injury or loss of material.



Icon	Meaning
	Prohibited (Next to this icon)
	Compulsory - The listed action must be implemented.
	Attention to what is indicated.





INSTALLATION WARNING

 Professional installer required	The heat pump must be installed by qualified personnel. Improper installation could result in electrical shock /water leakage or fire.
 Earthing is required	Please ensure that the unit and power connections have a good earth. Fail to do this may cause an electrical shock.
 Check drainage fittings	Before installation, make sure there are no leakages on the drainage fittings.



1. Safety Precautions

 Installation place	The unit CANNOT be installed near flammable gas.
 Fixing the unit	Ensure that the base you are fixing to is level and strong enough.
 Circuit breaker required	This unit requires a circuit breaker. failure to do so could result in an electrical shock or fire.

OPERATION WARNING

 Prohibited	Do not put fingers or any other objects into the fans. Children should be kept clear of this appliance.
 Shut off the power	In the event of a unit malfunction please shut the power off and contact your service engineer.

MOVE AND REPAIR

 Important	If the heat pump needs to be relocated or installed again, only use an authorised dealer or qualified personnel.
 Prohibited	It is prohibited for the end user to repair the unit themselves, unless qualified. fail to do so may lead to serious injury or/and damage to the unit.
 Important	Should the heat pump need to be repaired, only use an authorised dealer or qualified persons.

OPERATION ATTENTION

 Shut off the power	Turn the power off before cleaning the unit.
--	--

USAGE WARNING

 Usage warning	<p>Danger - High temperature.</p> <p>Setting a too high temperature of outlet water can cause scalding! If the product need repair, please do not attempt to repair it by yourself. Inform the local vendors and send the barcode on the casing of the unit order to reach professional repair.</p>
--	---

2. Specifications

2.1 Appearance

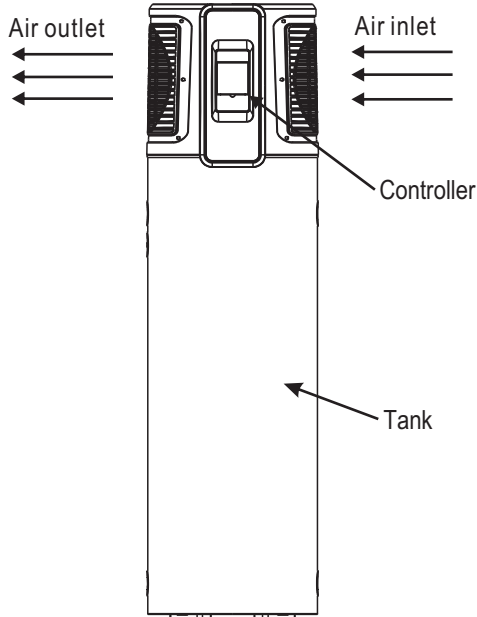

2.2 Characteristics

- Smart and efficient unit

The operational costs can be up to 75% less than that of an electric water heater, and can be installed in locations which are unsuitable for solar hot water heating.

- Safe and environmentally friendly

Produces no harmful gases along with no open flame, making the unit safe to work with when installing.

- Easy to operate

Featuring an easy-to-use timer for both start and stop operations, with a controller to set the desired water temperature.

2. Specifications

2.3 Principal

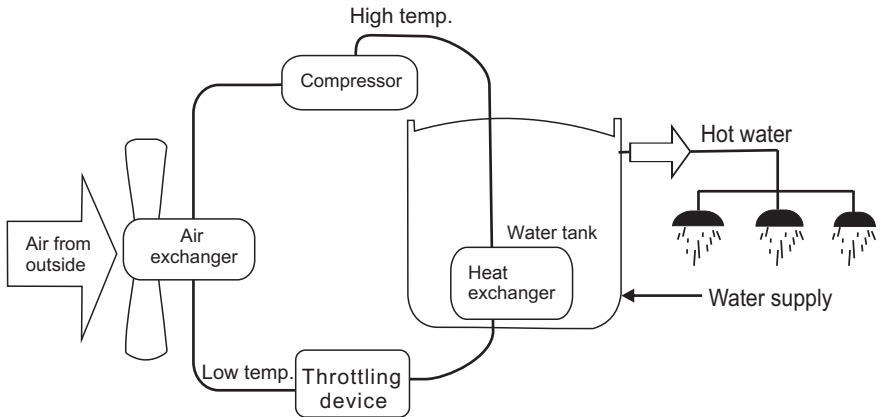

System Principle:

- ① Refrigerant is compressed into vapor with high temperature and high pressure when it goes through the compressor.
- ② On the discharge side of the compressor, the now hot and highly pressurized vapor is cooled down through the heat exchanger with the water in the tank until it condenses into a high pressure, moderate temperature liquid.
- ③ Then the pressure of the liquid refrigerant drops as it passes throttling device.
- ④ Finally, refrigerant absorbs heat from the surrounding air and evaporates into vapor with low temperature and low pressure and then it goes into compressor again.
- ⑤ The cooled surrounding air could be blown to the rooms which need fresh cooled air.

2. Specifications

2.4 dimensions

MODEL: ATMOSAIR 180

Unit: mm

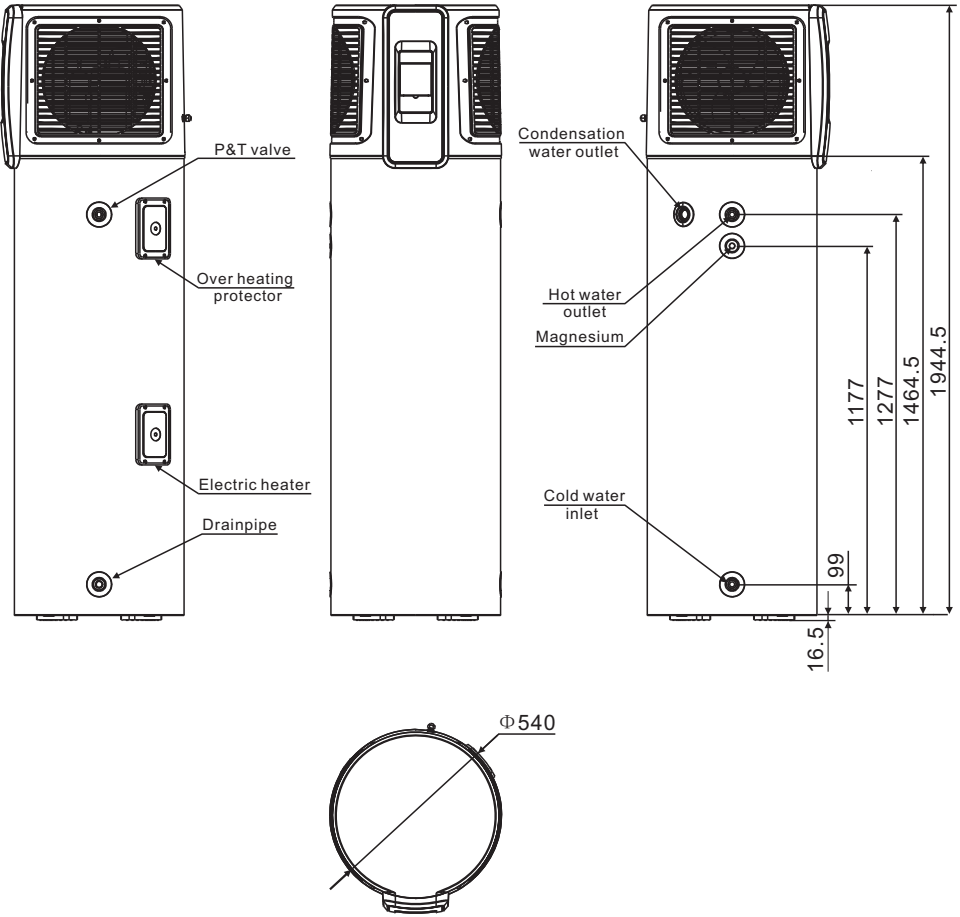

2. Specifications

2.5 performance parameters

Model		ATMOS AIR 180
Heating capacity	kW	1.7
Water tank capacity	L	180
Power input	kW	0.43
Running current	A	1.8
Power supply		240V~/50Hz
Compressor Number		1
Compressor		rotary
Rated outlet water Temp.		60
Nosie	dB(A)	See nameplate
Water inlet/outlet size	inch	3/4
*Auxiliary E-heater	kW	1.5
Net dimensions	mm	See the drawing of the units
Shipping dimensions	mm	See package label
Net weight	kg	See nameplate

Measurement conditions:

Instant heating: Ambient temperature 20°C/15°C, Water inlet 15°C, Water outlet 55°C

Work range

(1). Ambient temperature is -5°C~43°C (Heat Pump)

Operating parameters

The range of the operating water pressures: 0.15~0.7MPa

FREEZE PROTECTION

The water heater has a freeze protection system. The freeze protection system will protect the water heater from damage, by preventing ice forming in the waterways of the water heater, in the event of freezing conditions occurring.

3.Function presentation

Heating capacity

- In low ambient conditions the heating output decreases.

3 minutes protection

- If the unit stops and you restart the unit or turn it on by the manual switch, the unit will not start to run again for approx 3 minutes. This is a protection feature to safe guard the compressor.

Defrosting

- In the heating mode the unit will defrost automatically, maximizing the heating efficiency (Lasting 2 - 10 minutes).
The fan motor will stop running whilst the unit is defrosting.

Working conditions

- In order to use the unit correctly, please run the unit at environment temperature $-5^{\circ}\text{C}\sim 43^{\circ}\text{C}$. The unit includes sophisticated electronic devices, prohibited to use water from lake, untreated river water and groundwater!

Water temperature or pressure protection

- When the tank pressure reaches 0.85MPa or when the tank temperature reach 99 $^{\circ}\text{C}$, the P&T valve will open automatically so as to release the pressure or decrease the temperature.

4. Installation

Setup cannot affect the building structure and safety.

4.1 Pipeline connection sketch

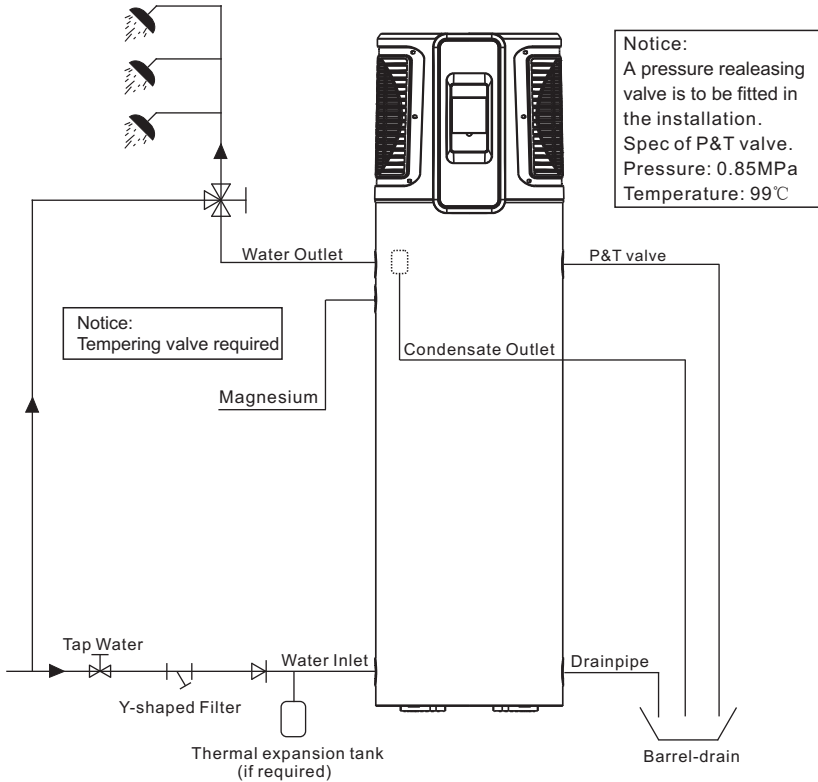

Pipeline connection explanation

Installation of the water inlet or outlet pipes: The specification of the water inlet and outlet thread is BSP3/4(internal thread).pipes must be heat-resistant and durable.

Installation of the pipe for P&T valve: The spec of the valve connecting thread is BSP3/4(internal thread). After installation, it must be confirmed that the drainpipe outlet is exposed in the air. When the flexible drainpipe is joined to the pressure relief orifice of this valve, you must ensure that the flexible drainpipe is pointing downwards and exposed in the air.



ATTENTION

ATTENTION: The Pressure release valve attached with the unit must be installed, fail to do so will cause damage to the unit, and possible personal injury.

Do not use stainless steel fittings to connect directly with other metals to prevent galvanic corrosion.

Drain the water tank through the drain valve at the bottom part of the unit.

4. Installation

WARNING

For continued safety of this appliance it must be installed, operated and maintained in accordance with the manufacturer's instructions.

If the water supply pressure exceeds the rated pressure, a pressure reducing valve is tube fitted when installing the unit.

The water may drip from the discharge pipe of the pressure relief device and that this pipe must be left open to the atmosphere.

The pressure relief device should be operated regularly to remove lime deposits and verify that it is not blocked.

A discharge pipe connected to the pressure relief device is to be installed in a continuously downward direction and in a frost-free environment.

Facilities for draining and filling of systems shall be provided where these are required for servicing purposes. The drainage facilities, where fitted, shall be at the lowest point in the closed circuit.

4.2 Transportation

As a rule, the unit is to be stored and/or transported in its shipping container in the upright position and without water charge. For transport over short distance, and provided due care is exercised, an inclination angle of up to 30 degrees is permitted. Both during transport and storage, ambient temperatures of -5°C to 43°C are permissible.

4.2.1 Transport using a fork lift

When transported by a fork lift, the unit must remain mounted on the pallet. The lifting rate should be kept to a minimum. Due to its top-heaviness, the unit must be secured against tipping over. To prevent any damage, the unit must be placed on a level surface!

4.2.2 Manual transport

For the manual transport, the wooden pallet can be used for bottom part.

Using ropes or carrying straps, a second or third handling configuration is possible. With this type of handling, care must be taken.

Permissible inclination angle of 60 degrees is not exceeded. If transport in an inclined position cannot be avoided, the unit should be placed into operation one hour after it has been moved into final position.



CAUTION High center of gravity!

4. Installation

4.3 Installation space

Before installation, please ensure that you leave the space as shown below for maintenance.

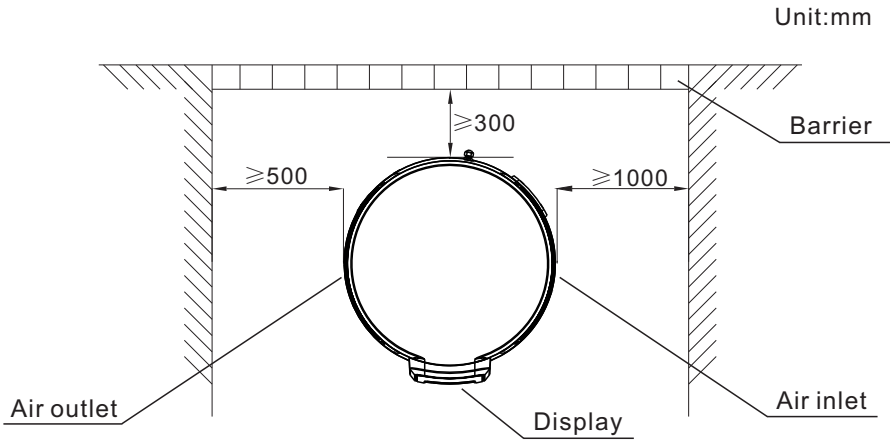

CAUTION :The minimum space of installation is 10 cubic meter.

4. Installation

Unit:mm

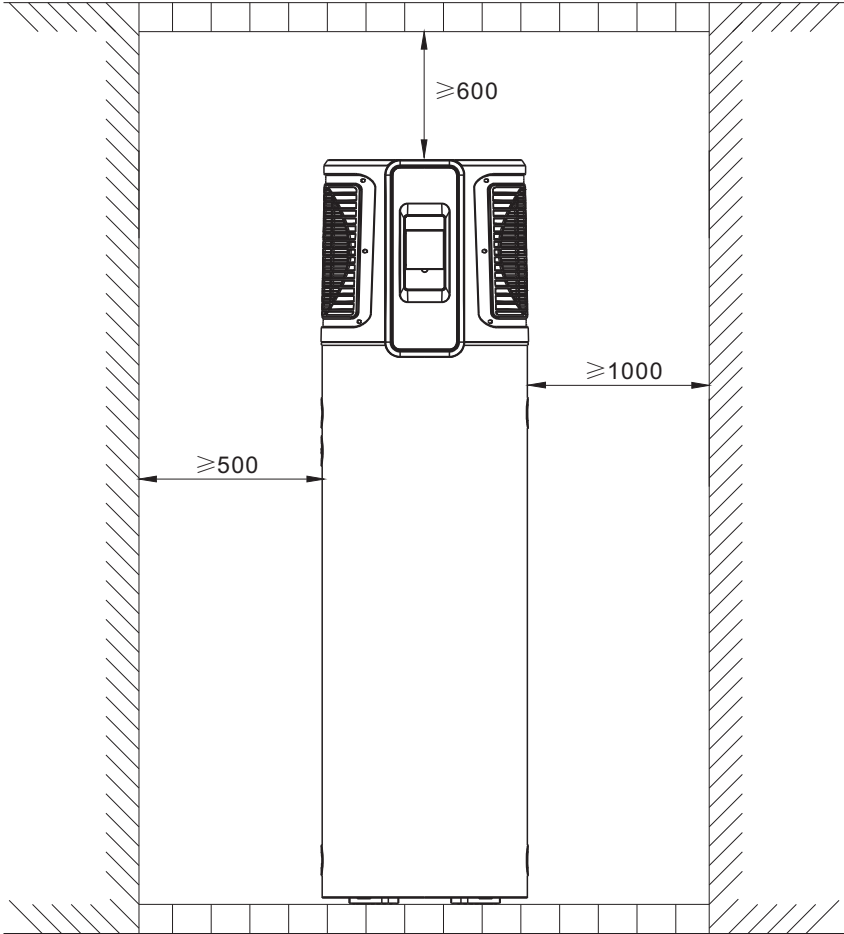

4. Installation

4.4 Cable connection

- This unit requires an isolating switch as required by local by laws.
- If the power cord is damaged, It must be replaced by a qualified electrician.

4.5 Trial running

4.5.1 Inspection before trial running

- Check the water supply to the tank and pipe connections for possible leaks.
- Check that all power connections are secure before switching on.

4.5.2 Trial running

- Switch on the unit using the controller
- In the case of any unusual noise, switch the power off and consult your provider;
- The parameters have been pre set to a temperature of 60 degrees.

4.6 Seismic restraints

- The unit must be braced with with seismic restraints according to local by laws.

5.Usage





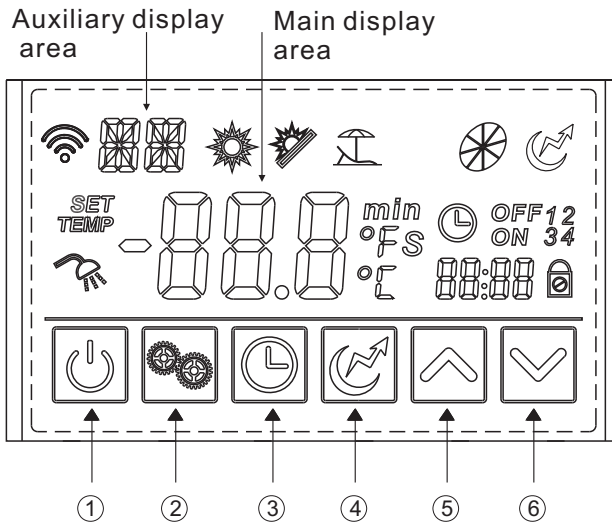



5.1 The function diagram of the wire controller

1.Function of wire controller



NO.	Button	Name	Function
①		ON/OFF	Turn on/off the unit.
②		Mode	Switch unit running modes or save setting parameters.
③		Clock	Set the clock or the timer.
④		Electric Heater	Turn on/off the electric heater or switch fan modes.
⑤		Up	Move up or increase parameter values.
⑥		Down	Move down or decrease parameter values.

5.Usage

Status icon	Name	What it means
	Heating	Shows that the unit is in heating mode.
	Eco.heating	Shows that the unit is in eco.heating mode.
	Vacation	Shows that the unit is in vacation mode.
	Fan	Shows that the fan is on and the speed of the fan.
	Electric heater	Shows that the electric heater is on.
	Set temperature achieved	Shows that the water temperature has reached the target point and the unit shut off automatically.
<i>SET</i>	Parameter setting	Shows that the parameter is adjustable.
<i>TEMP</i>	Temperature	Shows that the temperature is non-adjustable (measured value).
	Timer & ON	Shows that the unit will be turned on by the timer automatically.
	Timer & OFF	Shows that the unit will be turned off by the timer automatically.
<i>min</i>	Minute	Shows that the main display area displays the minute.
<i>S</i>	Second	Shows that the main display area displays the second.
<i>°C</i>	Centigrade	Shows that the temperature in Main display area or Auxiliary display area is in °C.
<i>°F</i>	Fahrenheit	Shows that the temperature in Main display area or Auxiliary display area is in °F.
	Lock	Shows that the keyboard is locked.

5.Usage

5.2 Usage of wire controller

5.2.1 Turn ON/OFF the unit

Press "⏻" and hold for 0.5s in the standby interface of the wire controller to turn on the unit and at this time the main display area shows the water outlet temperature.

Press "⏻" and hold for 0.5s in the running interface of the wire controller to turn off the unit and at this time the main display area shows OFF.

Note: The ON/OFF button can only be used to turn on/off the unit in standby or running interface of the wire controller.

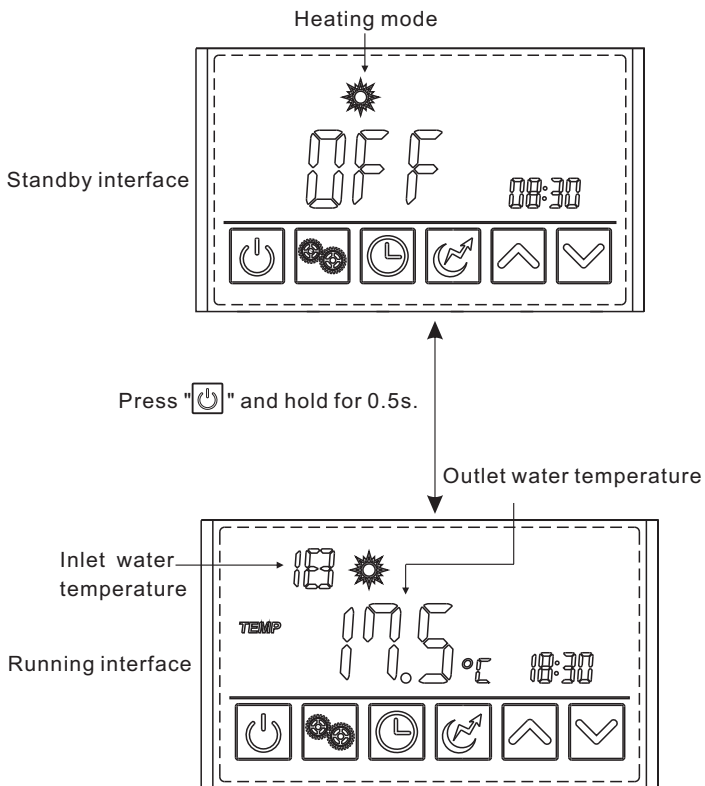

5.2.2 Mode selection

Press "⚙️" to select the mode from Heating ,Eco.heating ,Vacation, Intelligent , High requirement in the standby or running interface.

For example:

5.Usage

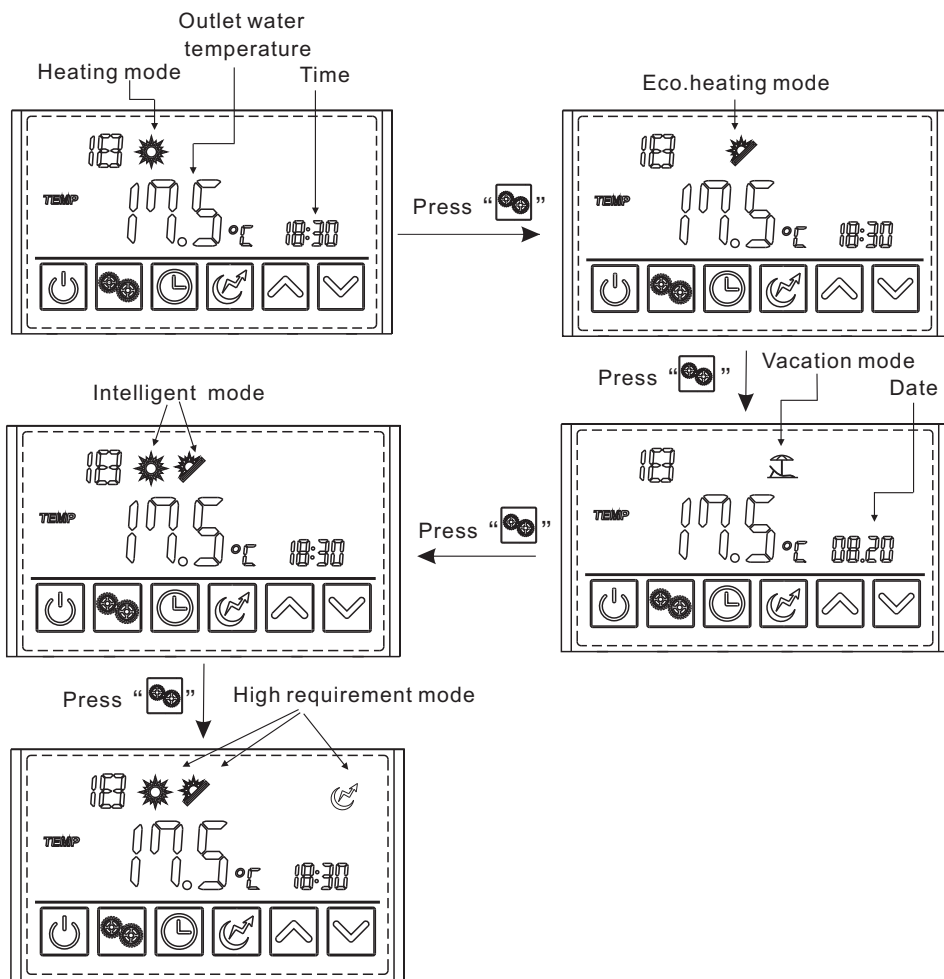

5.2.3 Target temperature checking and setting

In the standby or running interface, press "▲" or "▼" once to check the target temperature of the outlet water. Press "▲" or "▼" again to change the target temperature. After making the changes to the parameter, press "⊕⊖" to confirm or "⏻" to cancel the changes, then return to the previous interface. If no operations are performed on the keypad for 5s, the controller exits the parameter modification menu by timeout and the changes are confirmed.

Setting 75°C: When the target temperature is adjusted to 60 °C, press and hold the "▲" for 5s. At this time, the target temperature is displayed as 61 °C and the temperature range changed to 38-75°C. Press the "▲" to set the target temperature to 75 °C.

Example: Change the target temperature from 55°C to 70°C when the actual outlet water temperature is 18°C.

5. Usage

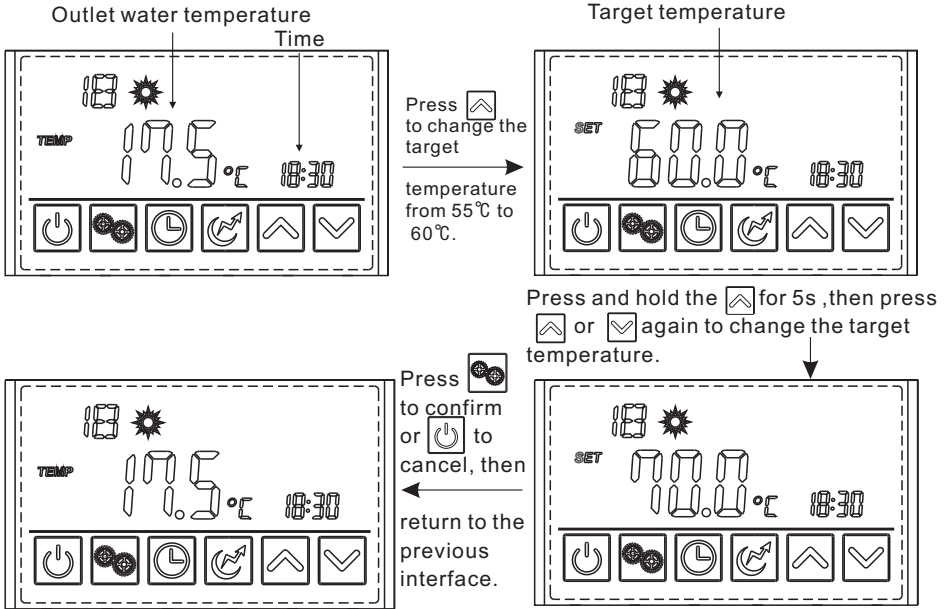

5.2.4 Time setting

In the standby or running interface, do as follows to set the time when in heating mode. When press "" once, the time parameter will flash. When press "" again, the hour parameter will flash then press "" or "" to change it. After making the changes to the parameter, press "" to confirm, then change the minute parameter as well as the date parameter in the same way.

If no operations are performed on the keypad for 15s, the controller exits the parameter modification menu by timeout and the changes are confirmed.

Note: Set the date in the same way when in vacation mode.

Example: Change the time and date from 18:30 on August 4th to 17:40 on September 8th.

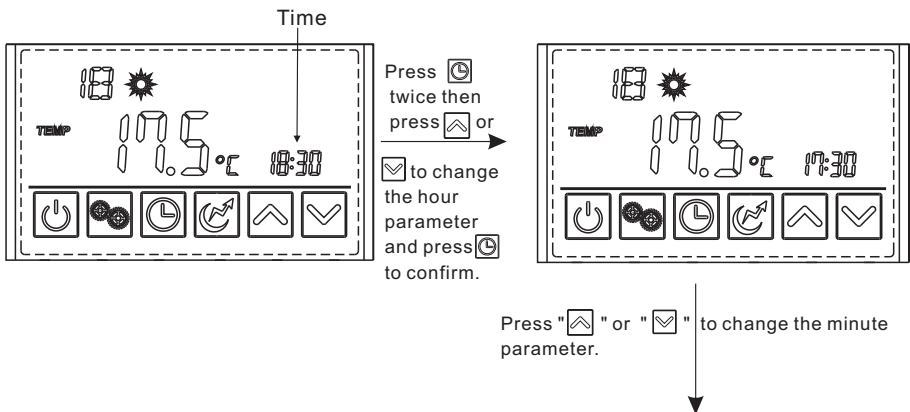

5. Usage

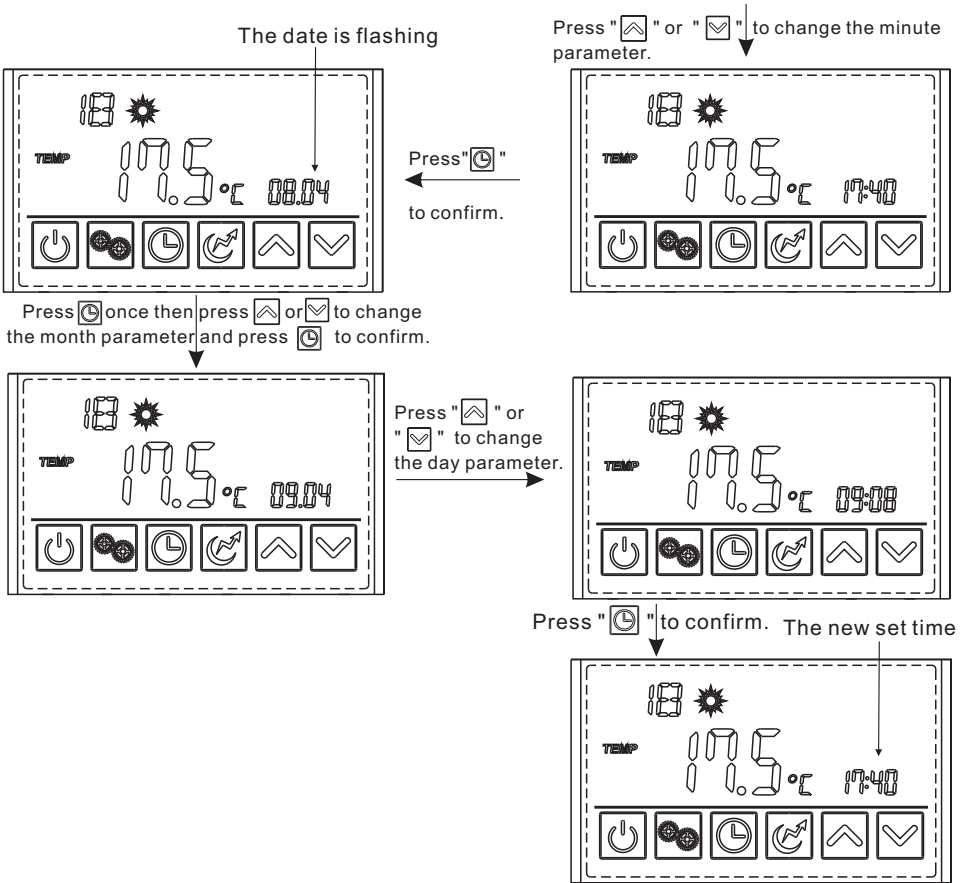

5.2.5 Timer setting

5.2.5.1 Under the standard mode, economic mode, intelligent mode, you can enter the timer setting.

Press "⏸" and hold for 2s, the "ON" and "1" will flash, and then you can set the turn on time of timer1 as the 24 clock setting show. After finishing, "OFF" and "1" will flash, that means you can set the turn off time of timer1. The "ON" and "2" will flash after finishing the timer1 setting, you can set the turn on time of timer2. After finishing, the "OFF" and "2" will flash, and then you can set the turn off time of timer2. Press "⏸" again to save and back to the interface. If you don't need to set the timer2, you can press the "⏸" to save after finishing the timer1 setting. You will find the "ON" and "2" flash. No operation for 5s, the program will back to the interface automatically.

Note: When press "⏸" and hold for 2s, the "ON" and "1" will flash. It is not necessary for you to set the turn on time of the timer1. You can sequentially to press "⏸" for 2s to enter to the turn off time of timer1. So does the timer2. Or press "⏪" or "⏩" to circularly display.

Timer Cancel: Press "⏸" and hold for 2s to enter into the interface, and then press "⏻" to cancel all the operation. Please see the following picture for more details.

5. Usage

Heating mode

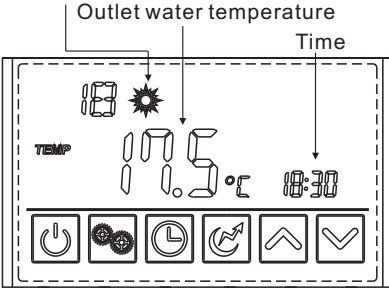

Press and hold for 2s.

Press " " to cancel the setting

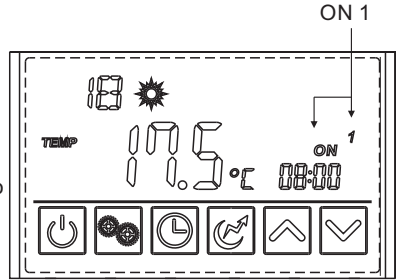

Press " " and hold for 2s to enter into the next setting without confirm the previous one.

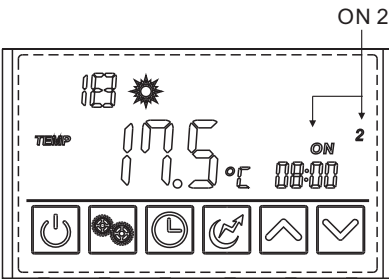

Press " " and hold for 2s to enter into the next setting without confirm the previous one.

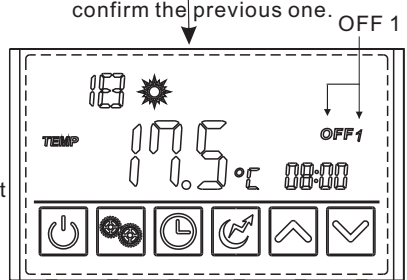

Press " " and hold for 2s to enter into the next setting without confirm the previous one.

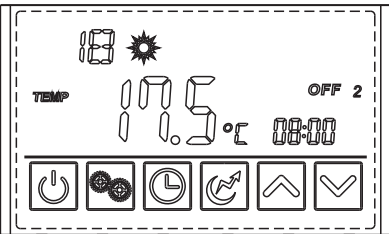

Set the hour.

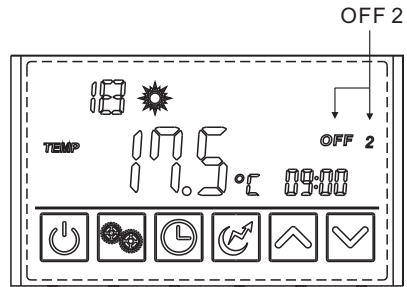

Set the minute.

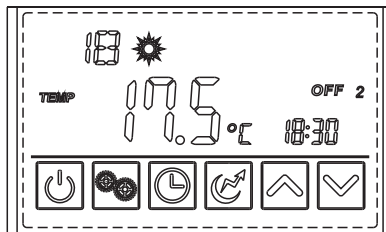

Press to confirm the time.

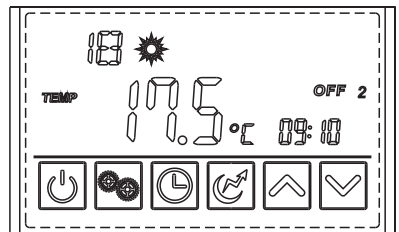

5. Usage

Example: **Running period 1:** 8:00~10:00; **Running period 2:** 16:30~20:00.

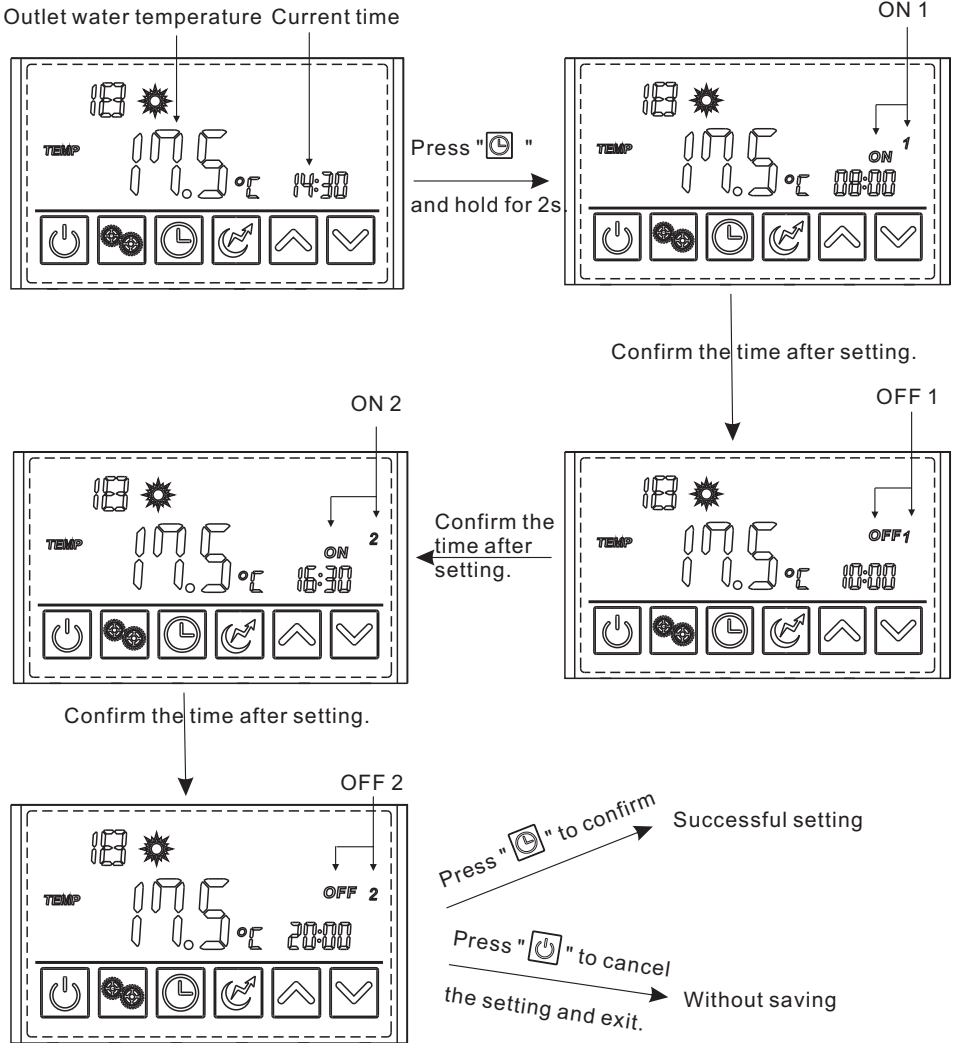

5.Usage

5.2.5.3 If you want to cancel the timer setting ,follow this below

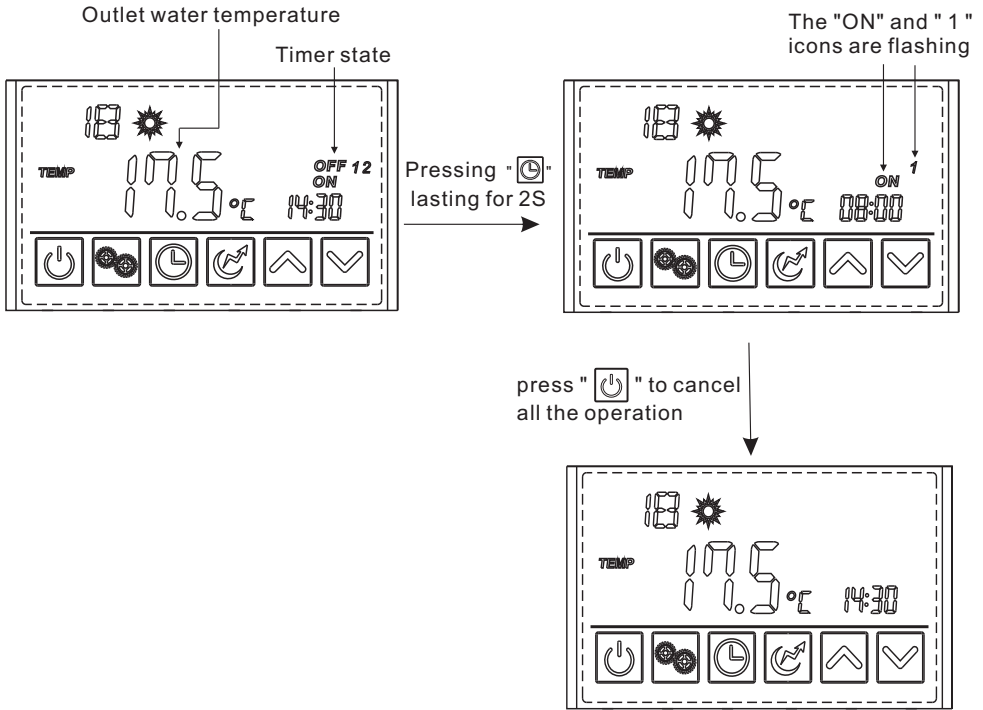

5. Usage

5.2.6 Electric heater setting

The electric heater can be turned on when the unit is heating or standby.

Press "🔥" once to turn on the electric heater and press "🔥" again to shut it off.

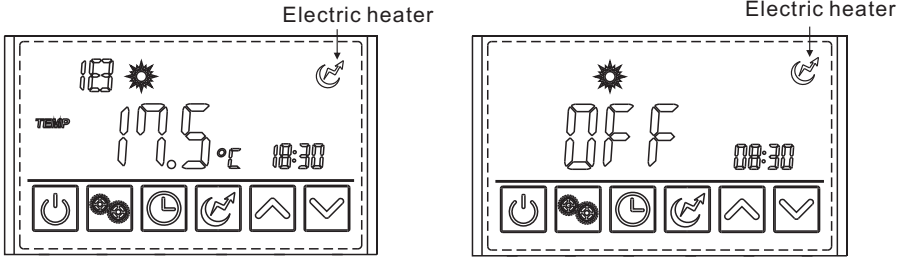

5.2.7 Keyboard locking

Press "🔌" and hold for 5s once to lock the keyboard. Press "🔌" and hold for 5s again to unlock the keyboard.

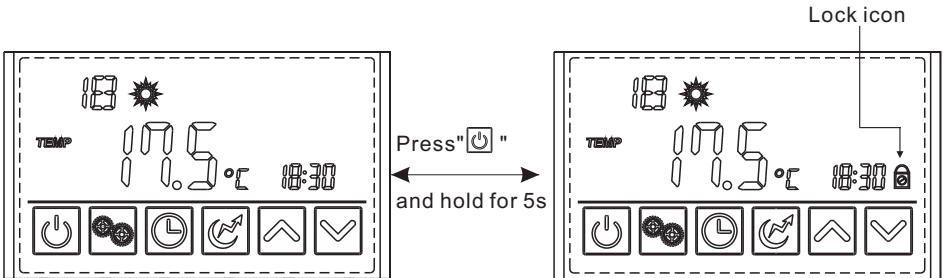

6.Maintenance and repair

6.1 Maintenance

- Check the water supply and air vent frequently, to avoid lack of water or air in the water loop. Clean the water filter periodically, helping the water to stay clean. Lack of water and dirty water can damage the unit.

- Keep the unit in a place which is dry and clean, and has good ventilation. Clean the heat exchanger (water tank) every 1 to 2 months to keep a good heat exchange rate.
- Check each part of the unit and the pressure of the system. Evacuate and recharge the refrigerant if it is needed.
- Check the power supply and the electrical system, make sure the electrical components are good, the wiring is tight.

- If the heat pump is not used for a long time, please drain out all the water in the unit and seal the unit. Please drain the water from the lowest point of the heat exchanger (water tank) to avoid freezing in winter. Water recharge and full inspection on the heat pump is needed before it is restarted.

- Don't power off the unit when you use it incontinually in cold weather, or the water in the pipe will freeze and split the pipe.
- If the power supply cord is damaged, it must be replaced by the manufacturer or its service agent or a similarly qualified person in order to avoid a hazard.
- Steps for replacing the magnesium rod:
Check the state of the magnesium rod half a year according to the following steps and we suggest that the magnesium rod should be replaced once a year.
When the diameter of the magnesium rod is less than 5 mm and the length is less than 100mm, please replace it immediately.
Step 1: Disconnect the power supply, close the water inlet of the unit, and then open the water outlet to release the pressure in the water tank till no water come out of the outlet.
Step 2: Open the water drain valve at the bottom of the unit, empty the water tank and replace the magnesium rod.
Step 3: After the replacement, close the drain valve, keep the water outlet opened, then open the water inlet to fill water to the tank until there is water flow out from the water outlet.

6. Maintenance and repair

6.2 The normal failure and solutions

For any malfunctions, please refer to the table below :

Malfunction	Display	Case	Solution
Bottom water temp. failure	P01	The water bottom temp. sensor is open or short circuit	Check or change the water bottom temp. sensor
Top tank water temp. failure	P02	The water top tank temp. sensor is open or short circuit	Check or change the water top tank temp. sensor
Ambient temp. failure	P04	The ambient temp. sensor is open or short circuit	Check or change the ambient temp. sensor
Coil temp. failure	P05	The pipe temp. sensor is open or short circuit	Check or change the pipe temp. sensor
Refrigerant absorb temp. failure	P07	The evaporator temp. sensor is open or short circuit	Check or change the evaporator temp. sensor
Anti-freeze temp. failure	P09	The anti-freeze temp. sensor is open or short circuit	Check or change the anti-freeze temp. sensor
Solar temp. failure	P034	The solar temp. Sensor is open or short circuit	Check or change the solar temp. sensor
High pressure protection	E01	The exhaust pressure is high , high pressure switch action	Check high pressure switch and cooling return circuit
Low pressure protection	E02	The suction pressure is low, Low pressure switch action	Check low pressure switch and cooling return circuit
Water flow failure	E03	No water or litter water in water system	Check the flow volume ,water pump is failure or not
Electric-heater overheat protection	E04	Water flow volume not enough,Water system pressure difference is small	Check the flow volume,water system is jammed or not
Anti-freeze protection	E07	Water flow volume not enough,Water system pressure difference is small	Check the flow volume,water system is jammed or not
Communication failure	E08	Wired remote control with master signal failure	Check the connection line between the wired remote control and motherboard
Winter frost protection	E09	Ambient temperature is too low	

6. Maintenance and repair

6.3 MAJOR SERVICE EVERY FIVE YEARS

It is recommended a major service be conducted on the water heater every five (5) years.

 **Warning:** Servicing of a water heater must only be carried out by qualified personnel. Phone your nearest Solahart Dealer.

Note: The major service and routine replacement of any components, such as the anode and relief valve(s), are not included in the Solahart warranty. A charge will be made for this work. Only genuine replacement parts should be used on this water heater.

The major service includes:

- Replace the temperature pressure relief valve.
- Inspect and flush the expansion control valve (if fitted). If required, replace the valve.
- Inspect and if required, replace the anode.
- If the anode is not replaced, it should be replaced within one (1) year of this service
- Check the electric heating unit for excessive calcium build-up or corrosion and replace if necessary.
- Check and inspect the heat pump module for operation.
- Visually check the unit for any potential problems.
- Inspect all connections.
- Check the condensate drain.

Note: The water heater may need to be drained during this service. After the completion of the service, the water heater will take some time to reheat the water. Depending upon the power supply connection, hot water may not be available until the next day.

HEAT PUMP SYSTEM

It is recommended the evaporator and refrigeration system is checked every five (5) years. In particularly dusty environments, it may be necessary to have the heat pump system checked and cleaned of dust and residue on a more regular basis.

6.4 WATER SUPPLIES, WATER CHEMISTRY AND WATER QUALITY

This water heater must be installed in accordance with this advice to be covered by the Solahart warranty.

This water heater is manufactured to suit the water conditions of most public reticulated water supplies. However, there are some known water chemistries which can have detrimental effects on the water heater and its operation and / or life expectancy. If you are unsure of your water chemistry, you may be able to obtain information from your local water supply authority. This water heater should only be connected to a water supply which complies with these guidelines for the Solahart warranty to apply.

6. Maintenance and repair

CHANGE OF WATER SUPPLY

The changing or alternating from one water supply to another can have a detrimental effect on the operation and / or life expectation of a number of components in this water heater.

Where there is a change over from one water supply to another, e.g. a rainwater tank supply, bore water supply, desalinated water supply, public reticulated water supply or water brought in from another supply, then water chemistry information should be sought from the supplier or it should be tested to ensure the water supply meets the requirements given in these guidelines for the Solahart warranty to apply.

CAUTION

If the water supply has a TDS greater than 150 mg/L and a green anode has not been changed to a black anode, or if the TDS is greater than 600 mg/L and the anode has not been changed to a blue anode, there is the possibility the anode may become overactive and hydrogen gas could accumulate in the top of the water heater during long periods of no use.

If, under these conditions, the water heater has not been used for two or more weeks the following procedure should be carried out before using any electrical appliances (automatic washing machines and dishwashers) which are connected to the hot water supply.

The hydrogen, which is highly flammable, should be vented safely by opening a hot tap and allowing the water to flow. There should be no smoking or naked flame near the tap whilst it is turned on. Any hydrogen gas will be dissipated. This is indicated by an unusual spurting of the water from the tap. Once the water runs freely, any hydrogen in the system will have been released.

SATURATION INDEX

The saturation index (SI) is used as a measure of the water's corrosive or scaling properties. The saturation index figures stated are calculated using a water temperature of 80°C.

Where the saturation index is less than -1.0, the water is very corrosive and the Solahart warranty does not apply to the water heater. In a corrosive water supply, the water can attack copper parts and cause them to fail.

Where the saturation index exceeds +0.40, the water is very scaling and the Solahart warranty does not apply to the water heater.

Water which is scaling may be treated with a water softening device to reduce the saturation index of the water.

CHLORIDE AND PH

Where the chloride level exceeds 250 mg/L the Solahart warranty does not apply to the water heater. In a high chloride water supply, the water can corrode stainless steel parts and cause them to fail.

6.Maintenance and repair

Where the pH is less than 6.0 the Solahart warranty does not apply to the water heater. pH is a measure of whether the water is alkaline or acid. In an acidic water supply, the water can attack stainless steel parts and cause them to fail.

Water with a pH less than 6.0 may be treated to raise the pH. The water supply from a rainwater tank in a metropolitan area is likely to be corrosive due to the dissolution of atmospheric contaminants.

SUMMARY OF WATER CHEMISTRY ADVICE AFFECTING WARRANTY

The water heater is not suitable for certain water chemistries. Those chemistries are listed below. If the water heater is connected at any time to a water supply with the following water chemistry, the Solahart warranty will not cover any resultant faults:

Water Chemistry	Component
Total Dissolved Solids (TDS) > 2500 mg/L	Water heater cylinder
Total Dissolved Solids (TDS) not suitable for anode type	Water heater cylinder
Saturation Index (SI) < -1.0	Water heater
Saturation Index (SI) > +0.4	Water heater
Chloride > 250 mg/L	Water heater
pH < 6.0	Water heater

6.5 Product Warranty:

- 2 Years on cylinder
- 2 Years on Heat Exchanger, Gas System, Compressor / sealed systems
- 1 Year on other components

The decision of whether to repair or replace a faulty component is at Solahart's sole discretion. This warranty is void if there is:

a.Fail to maintain the water heater in accordance with the Owner's Guide and Installation Instructions

b.Transport damage.

c.Fair wear and tear from adverse conditions (for example, corrosion).

d.Cosmetic defects.

e.Ice formation in the waterways of a water heater system incorporating a freeze protection system where the electricity supply has been switched off or has failed.

f.Where a failed component or cylinder is replaced under this warranty, the balance of the original warranty period will remain effective. The replacement does not carry a new Solahart warranty.

6. Maintenance and repair

g. Where the water heater is installed in a position that does not allow safe or ready access, the cost of that access, including the cost of additional materials handling and/or safety equipment, shall be the owner's responsibility. In other words, the cost of dismantling or removing cupboards, doors or walls and the cost of any special equipment to bring the water heater to floor or ground level or to a service able position is not covered by this warranty.

h. This warranty only applies to the original and genuine Solahart water heater in its original installed location and any genuine Solahart replacement parts.

i. The Solahart warranty does not cover faults that are a result of:

i. Accidental damage to the water heater or any component (for example: (i) Acts of God such as floods, storms, fires, lightning strikes and the like; and (ii) third party acts or commissions).

ii. Misuse or abnormal use of the water heater.

iii. Installation not in accordance with the Owner's Guide and Installation Instructions or with relevant statutory and local requirements in the State or Territory in which the water heater is installed.

iv. Connection at any time to a water supply that does not comply with the water supply guidelines as outlined in the Owner's Guide and Installation Instructions.

v. Repairs, attempts to repair or modifications to the water heater by a person other than the Solahart Dealer or a Solahart Accredited Service Agent.

vi. Faulty plumbing or faulty power supply.

7. Appendix

7.1 CAUTION

1. To reduce the risk of excessive pressures and temperatures in this water heater, install temperature and pressure protective equipment required by local codes and no less than a combination temperature and pressure relief valve certified by a nationally recognized testing laboratory that maintains periodic inspection of production of listed equipment or materials, as meeting the requirements for Relief Valves and Automatic Gas Shutoff Devices for Hot Water Supply Systems, ANSIZ21.22. This valve must be marked with a maximum set pressure not to exceed the marked maximum working pressure of the water heater. Install the valve into an opening provided and marked for this purpose in the water heater, and orient it or provide tubing so that any discharge from the valve exits only within 6 inches above, or at any distance below, the structural floor, and does not contact any live electrical part. The discharge opening must not be blocked or reduced in size under any circumstances.

2. Hydrogen gas is produced in a hot water system served by this heater that has not been used for a long period of time (2 weeks or more). Hydrogen gas is extremely flammable. To reduce the risk of injury under these conditions, it is recommended that the hot water faucet be opened for several minutes at the kitchen sink before using any electrical appliance connected to the hot water system. When hydrogen is present, there will probably be an unusual sound such as air escaping through the pipe as the water begins to flow. There should be no smoking or open flame near the faucet at the time it is open.

3. Children should be supervised to ensure that they do not play with the appliance.

4. The appliance is fitted with means for disconnection from the supply mains having a contact separation in all poles that provide full disconnection under overvoltage category III conditions, and these means must be incorporated in the fixed wiring in accordance with the wiring rules.

7. Appendix

7.2 The method of grounding

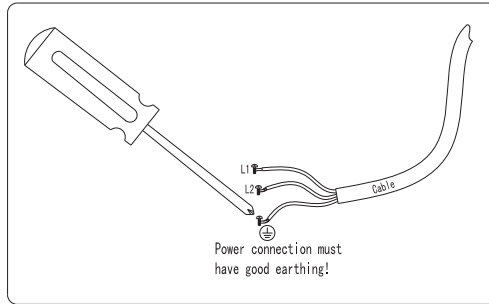

7.3 Use of the P&T valve

P&T valve is used to pressure going too high inside the tank. When the pressure reaches the set value, the valve will open automatically so as to release the pressure or decrease the temperature.

The handle of the safety valve should be pulled once every six months so as to remove the calcium carbonate deposition decrease the temperature. Take care as the temperature of the discharging water is very high.

Vent pipes should be thermally insulated to prevent the pipes freezing in the winter.

Remark:

P&T valve: action temperture: 99°C, action pressure:0.85MPa

WARNING

Fail to operate the relief valve easing gear at least once every six months may result in the water heater exploding. Continuous leakage of water from the valve may indicates problem with the water heater.

7. Appendix

7.4 Drain out the water in the storage tank

Cut out the water supply connection between the tap water supply and the tank by closing the corresponding valve. Open the hot water outlet and then open the drain outlet valve at the same time.

The water in the tank will be drained out through the drain outlet.

7.5 Use of the overheating protector

DANGER: The operation of the thermal cut-out indicates a possibly dangerous situation.

Do not reset the thermal cut-out until the water heater has been serviced by a qualified person.

The overheat protector is used to turn the power off, preventing the water from being heated too high. To return the unit to its normal operational status it will have to be reset manually.

Operation details:

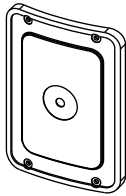

loosen the screws and open the cover



Press the red button to reset



Solahart Industries
Registered Office
1 Alan Street, Rydalmere
New South Wales 2116
Australia

Telephone International Sales: + 61 2 9684 9100
Facsimile International Sales: + 61 2 9684 9180
Email: solahart@solahart.com.au
Web: www.solahart.com